

1-800-639-2199

Fax (603) 224-2927

Headwall\Standard\Straight\Mass Highway\15 in_Pipe_Sales

Phoenix Precast Products

Phoenix Precast Products

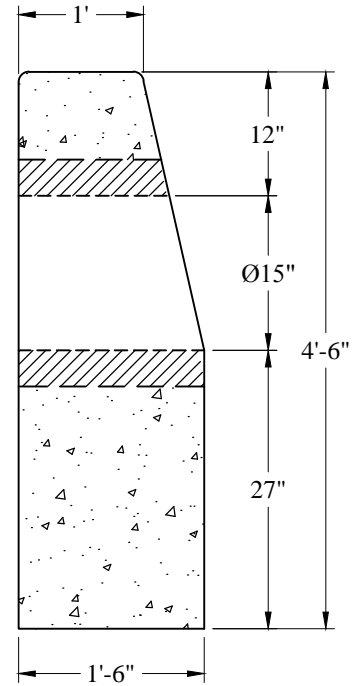
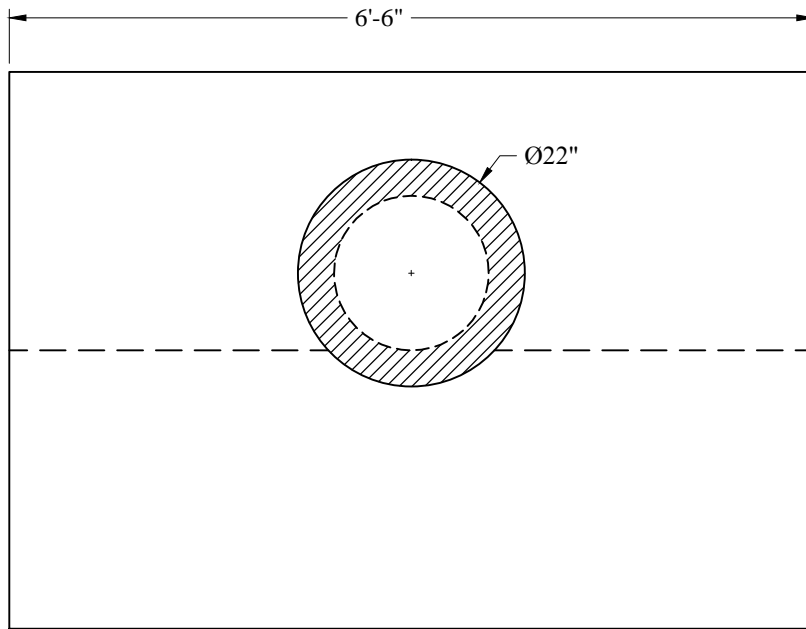

General Notes

1. Steel Reinforcement Conforms to Latest ASTM Specification: ASTM A-615
Grade 60 Black Deformed Bars
2. Concrete: $f_c = 4,000$ psi @ 28 Days Minimum
3. Est Weight: 5,400 Lbs

Phoenix
Precast
Products

Precast Headwall
Mass. Highway
15" Pipe

P/N: HW-MASS15